

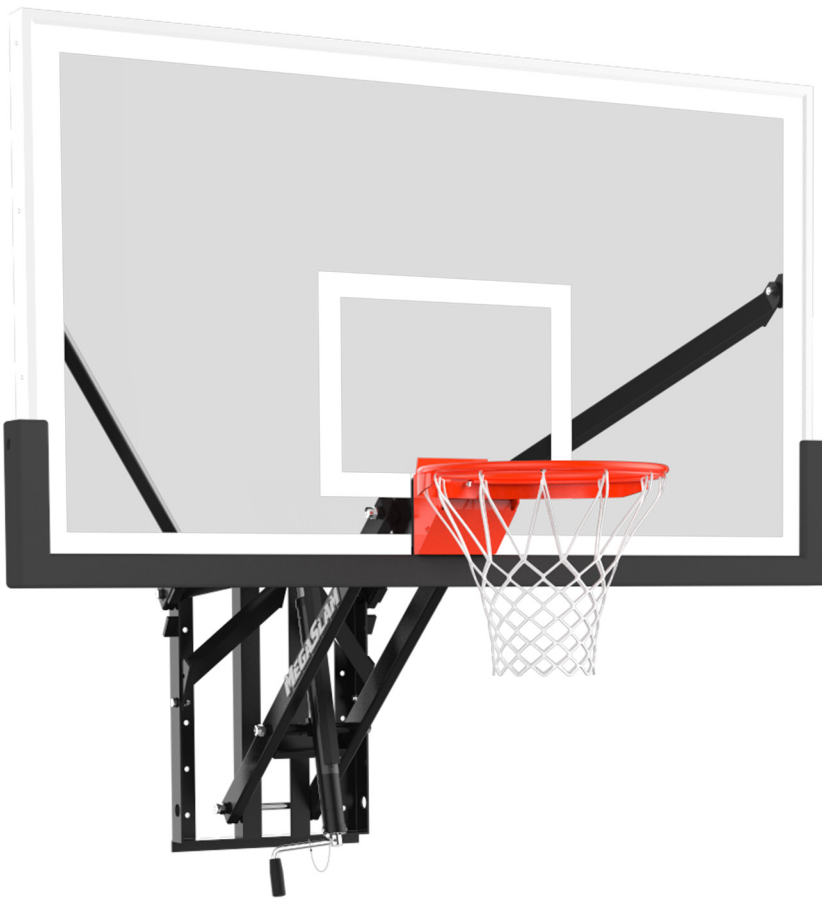

INSTALLATION AND OWNER'S INSTRUCTIONS



PROGYM 72

TABLE OF CONTENTS

| | |
|--|----|
| Safety Instructions..... | 2 |
| Goal Specifications..... | 3 |
| Hardware..... | 4 |
| Parts..... | 5 |
| Parts..... | 6 |
| Frame Assembly..... | 7 |
| Bracket / Actuator Assembly..... | 8 |
| Backboard Attachment..... | 9 |
| Rim & Height Indicator Attachment..... | 10 |
| Maintenance & Inspection..... | 11 |

1-877-321-MEGA
 www.megaslamhoops.com
 Copyright © Mega Slam Hoops, LLC
 All rights reserved. Unauthorized copying is prohibited by law without written permission.

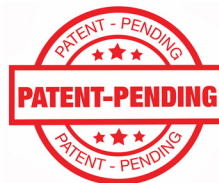

SAFETY INSTRUCTIONS

CAUTION

Owner/Purchaser must insure that all players have read these instructions and both know and follow these rules for the safe operation of the system.

To insure safety, DO NOT attempt to assemble this system without following the instructions carefully. Proper and complete assembly, use and supervision, and full understanding of the instructions are essential for proper operation and to reduce the risk of accident or injury. A high probability of serious injury exists if this system is not installed, maintained, and operated properly.

Proper and complete assembly, use and supervision is essential for proper operation of the product and to reduce the risk of accident or injury.

Use caution when using this goal system. Most injuries are caused by misuse and/or not following these instructions.

Only use parts provided by Mega Slam Hoops, LLC for installation as outlined in this manual as other parts may cause system to fail.

Consult a professional architect, engineer, or contractor to determine a safe wall anchoring system to match the wall construction being used in your application.

Installation of this product will require heavy lifting. (4) People in good physical condition and capable of lifting at least 90-100 lbs. (40-45 kg) each are recommended for safe installation and assembly.

Retain this manual for future reference of operation, maintenance and parts information. The information in this manual is based on the latest information available at the time of publication. Your goal may have product improvements and options not yet contained in this manual. Mega Slam Hoops, LLC reserves the right to make changes at any time without notice or obligation.

Keep water and organic material away from system as this could cause failure from rust/corrosion. Check system regularly for rust. If surface rust is found, remove the affected part and repaint with exterior enamel paint.

Contact the manufacturer if technical assistance is required. Additional copies of these instructions are available at www.megaslamhoops.com

WARNING

FAILURE TO FOLLOW THESE WARNINGS & INSTRUCTIONS MAY RESULT IN SERIOUS INJURY, DEATH, AND / OR PROPERTY DAMAGE

Locate your system away from potential dangers including trip hazards, high traffic areas, or where a vehicle may be in contact with the system.

To avoid serious injury, DO NOT locate the system under a power line that may come into contact with the system as it is raised. Power lines should not be present within a 20 foot radius of system.

Walls can contain electrical wires and other unseen hazards and obstacles. It is the installer's responsibility to locate and avoid these hazards during installation.

If using a ladder during assembly, use extreme caution. Follow all warnings and cautions on the ladder carefully.

Use caution when performing dunking activities with this product. During play, especially while performing dunking activities; keep players face away from the backboard and net. Serious injury could occur if teeth/face comes in contact with the backboard, rim, or net.

DO NOT HANG ON RIM!

During play, do not wear jewelry (rings, watches, necklaces, etc.) or other objects that could become tangled in the net.

Wear a dentist approved mouth guard when playing to avoid dental injuries.

DO NOT CLIMB OR HANG on the rim or any part of the goal system. This includes the backboard, support braces and net. The product is not designed for such use and property damage or personal injuries such as cuts, broken bones, nerve, spinal cord or brain injury or death could occur.

Do not use the system to lift anything. When adjusting the system height, keep hands/fingers away from moving parts. DO NOT ALLOW CHILDREN TO ADJUST SYSTEM.

Climate, corrosion, or misuse could result in system failure.

Check system before each use for loose hardware, signs of rust and instability. If the rust has penetrated the steel, replace that part immediately. Repair before each use. Never play on damaged equipment.

Goal Specifications

| | PRO GYM 72 | PRO GYM 60 |
|-------------------------------|------------|------------|
| Backboard size | 72" x 42" | 60" x 36" |
| Weight | 329 lbs. | 282 lbs. |
| Height Range | 6' to 10' | 6' to 10' |
| (A) Top of Frame Height | 116" | 116" |
| (B) Frame Height | 28" | 28" |
| (C) Height to Bottom of Frame | 88" | 88" |
| (D) Handle Height | 84" | 84" |
| (E) Handle Distance | 9" | 9" |
| (F) Overhang Distance | at 10' | 36" |
| | at 8' | 46" |
| | at 6' | 40" |
| (G) Front of Rim to Backboard | 25.3" | 25.3" |
| (H) Rim to Top of Backboard | 34" | 28" |

IMPORTANT

Mega Slam Hoops, LLC cannot assume liability for the installation of any wall mounted structure. The manufacturer recommends consulting a professional architect, engineer, or contractor to determine a safe wall anchoring system to match the wall construction being used in your application.

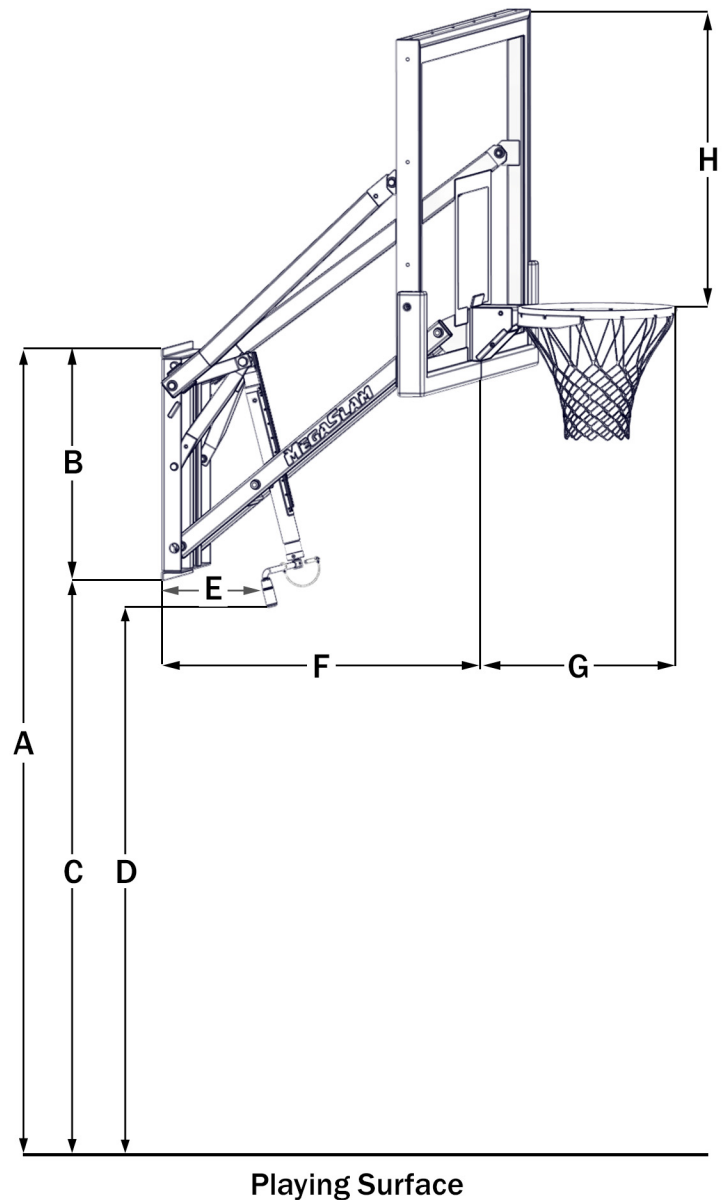

Planning & Preparation

1. Inventory and identify all parts and hardware using the Hardware List. Be sure to check all packaging materials for hardware and parts, and immediately contact Mega Slam Hoops if there are any missing parts.
2. Gather all of the items needed for assembly not included with the product.
3. Locate a suitable area for the playing court. Always keep safety in mind when selecting your location.
4. Your basketball system should be located to provide a paved, smooth, and level playing surface that is as far away from the street as possible to enable a safe playing environment.
5. The following factors should be evaluated prior to selecting a location:
 - Utilities near the mounting frame
 - Surrounding power lines (No overhead power lines should be within a 20 ft. radius of the system.)
 - The amount of playing surface desired surrounding the goal.
 - The basketball system will be a permanent structured once installed.
 - The playing surface must be free of any hazards or obstructions.



16mm x 5.25"
1 piece



12mm x 3"
2 pieces



12mm x 1.5"
4 pieces

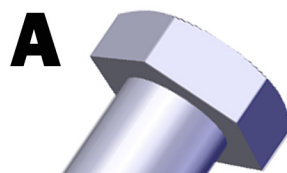

16mm x 10.75"
3 pieces

Rim Kit Hardware

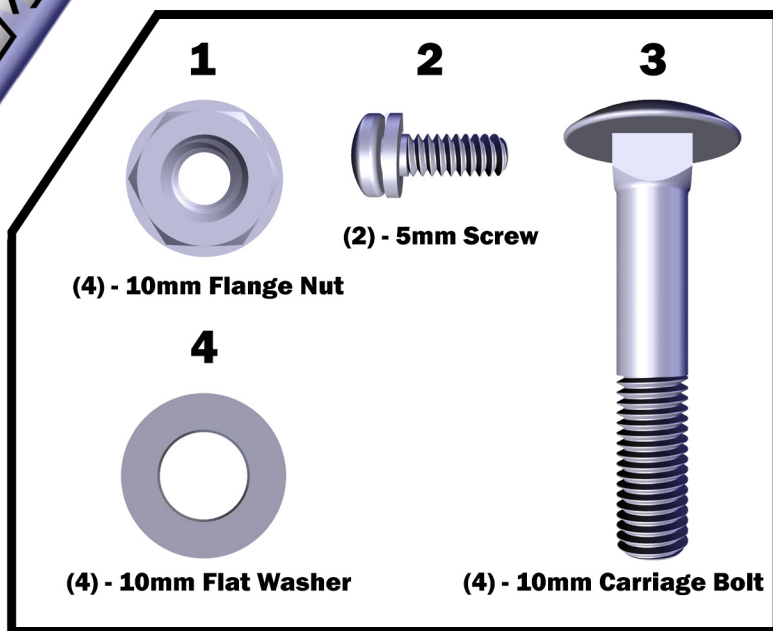

PRO GYM 72



Height Actuator



Height Indicator

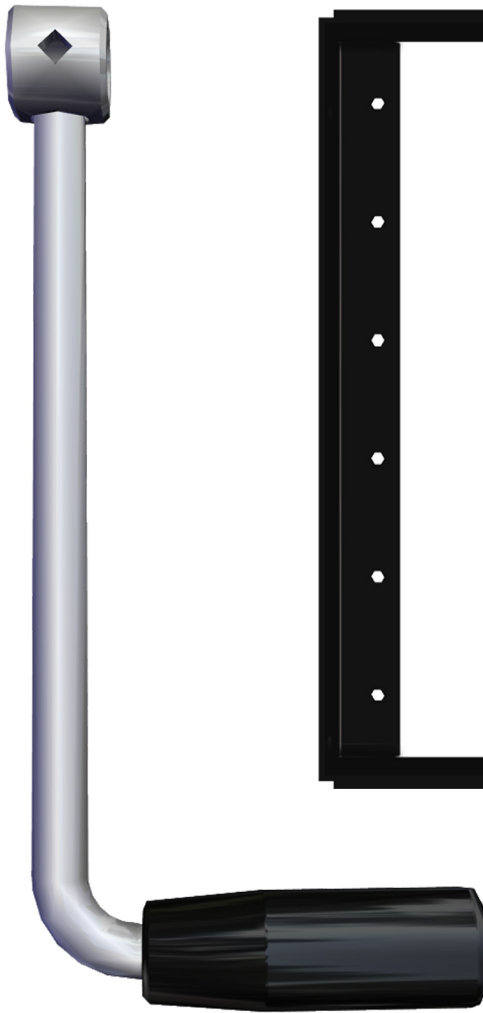

Adjustment Handle

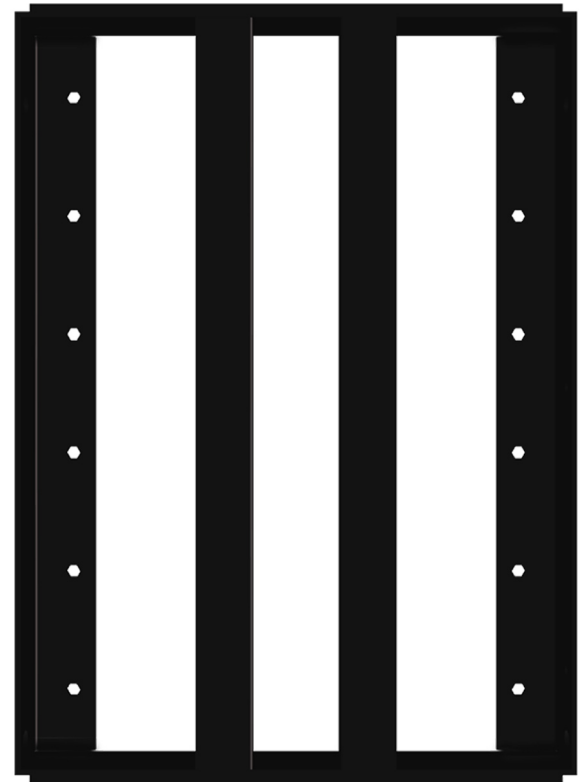

Wall Frame



**16mm Hex Nut
(4) Pieces**

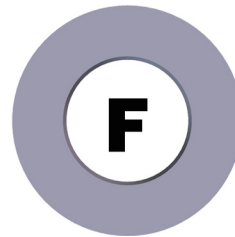

**16mm Flat Washer
(8) Pieces**



**16mm Nylon Washer
(6) Pieces**



**12mm Hex Nut
(6) Pieces**

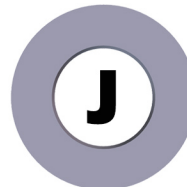

**12mm Flat Washer
(12) Pieces**



**12mm Nylon Washer
(10) Pieces**

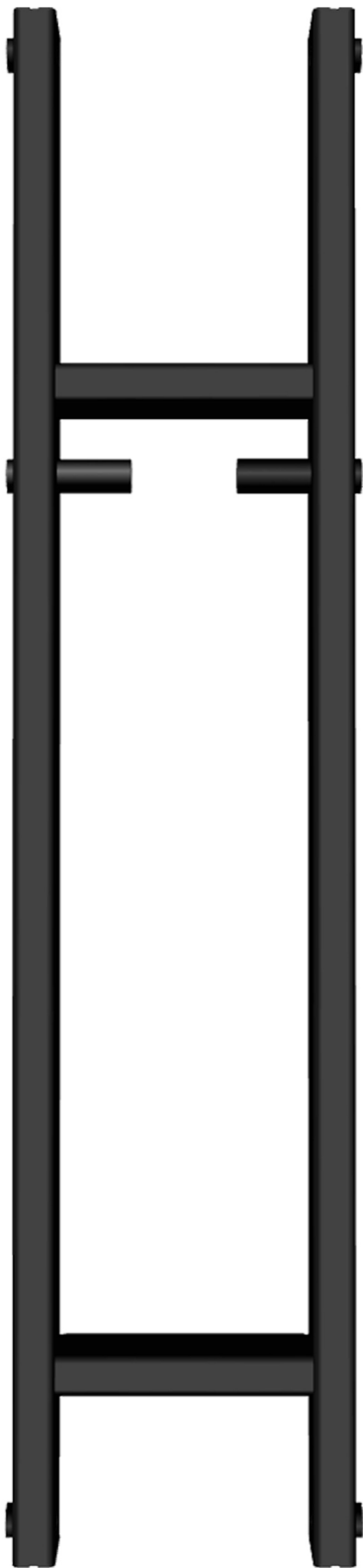

Lower Extension Arm

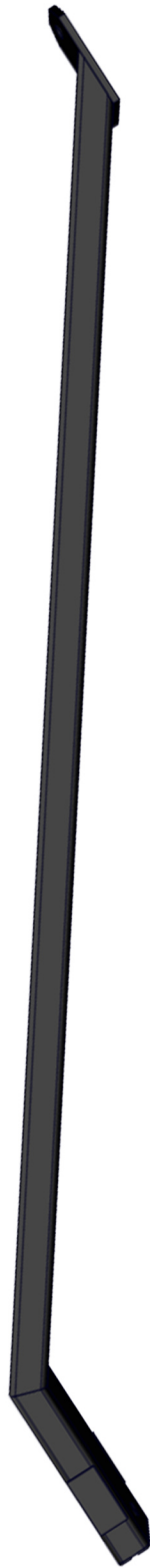

**Upper Extension Arms
2 Pieces**

**Upper Bracket for
Height Actuator Assembly
2 Pieces**

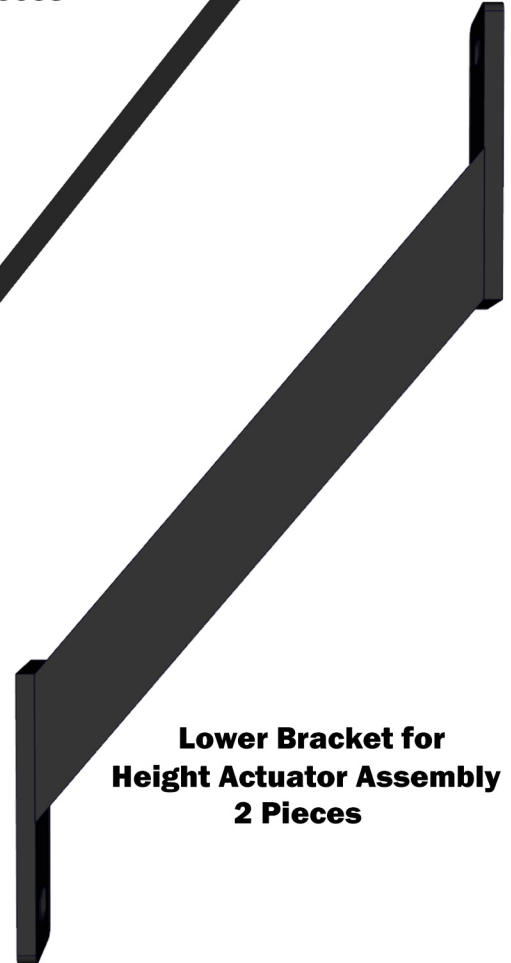

**Lower Bracket for
Height Actuator Assembly
2 Pieces**

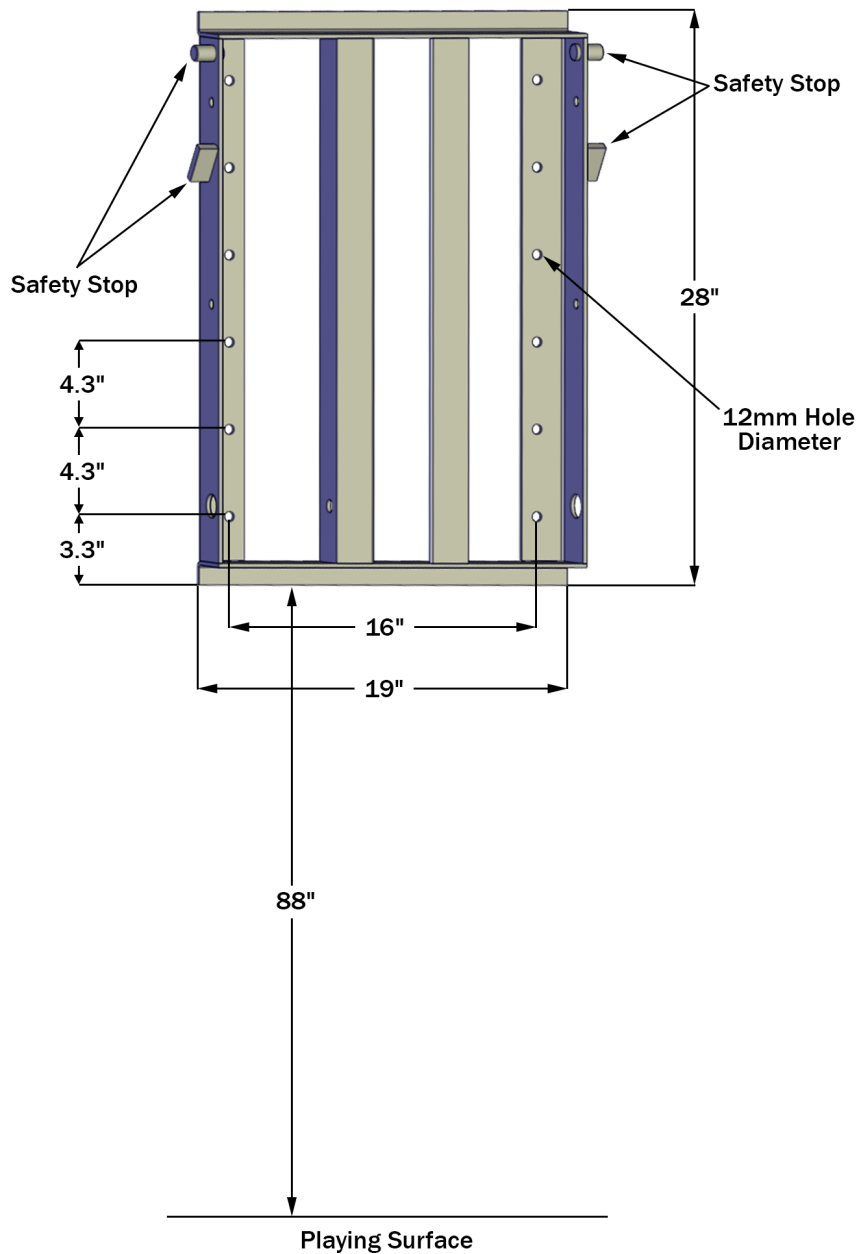

Sleeve for Height Actuator

STEP #1**Wall Frame Attachment****WARNING**

Wall hanging location is the responsibility of the customer and/or installer.

It is the responsibility of the customer and/or installer to determine how many of the frame's 12 mounting holes must be used to safely secure the wall mount goal for play.

Fasteners to be determined and provided by the customer and/or installer.

Walls can contain electrical wires and other unseen hazards and obstacles. It is the installer's responsibility to locate and avoid these hazards during installation. To avoid severe injury or death, do not locate goal under power lines.

Mark a horizontal line to the mounting surface 88" above from the playing surface.

Position and center frame bottom on the horizontal line with the frame's safety stops at the top.

Level wall frame vertically and horizontally, and mark the mounting holes needed for attachment.

Drill the appropriate size holes needed in the mounting surface based on the specific fastener being used to support the frame to the wall.

Attach frame to the wall using the fasteners making sure to level the frame before fully tightening and securing.

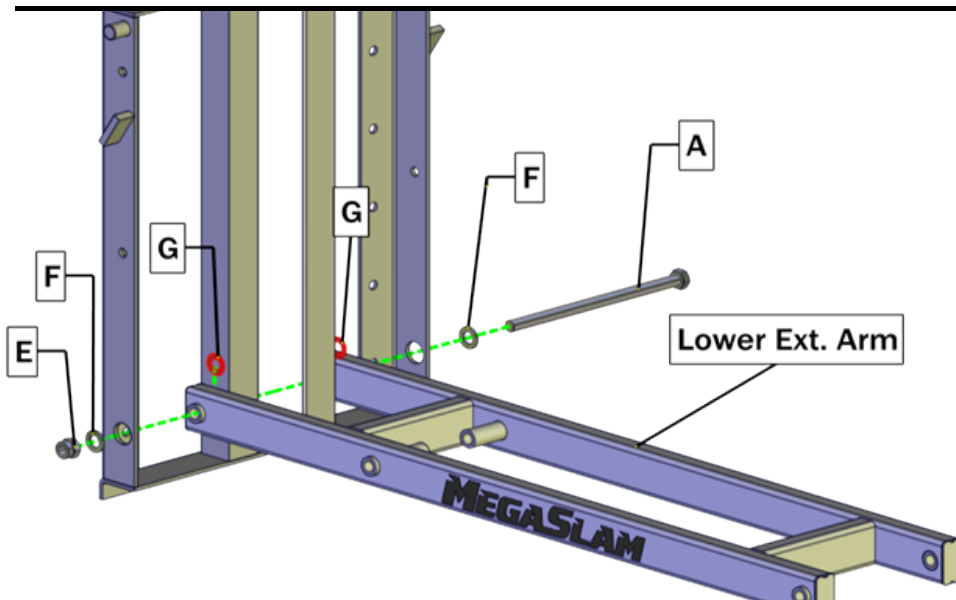
STEP #2**Lower Extension Arm**

Attach the lower extension arm to the frame assembly using the following:

Bolt "A" - 16mm x 10.75" (1)

"F" - 16mm steel washer (2)

"G" - 16mm nylon washer (2)

"E" - 16mm hex nut (1)

Do not overtighten as this is a pivot point of the system. Snug Tighten.

STEP #3 Lower Brackets

Attach the (2) lower brackets to the frame assembly using the following:

Bolt "B" - 12mm x 1.5" (2)

"J" - 12mm steel washer (4)

"I" - 12mm hex nut (2)

Do not overtighten as this is a pivot point of the system. Snug Tighten.

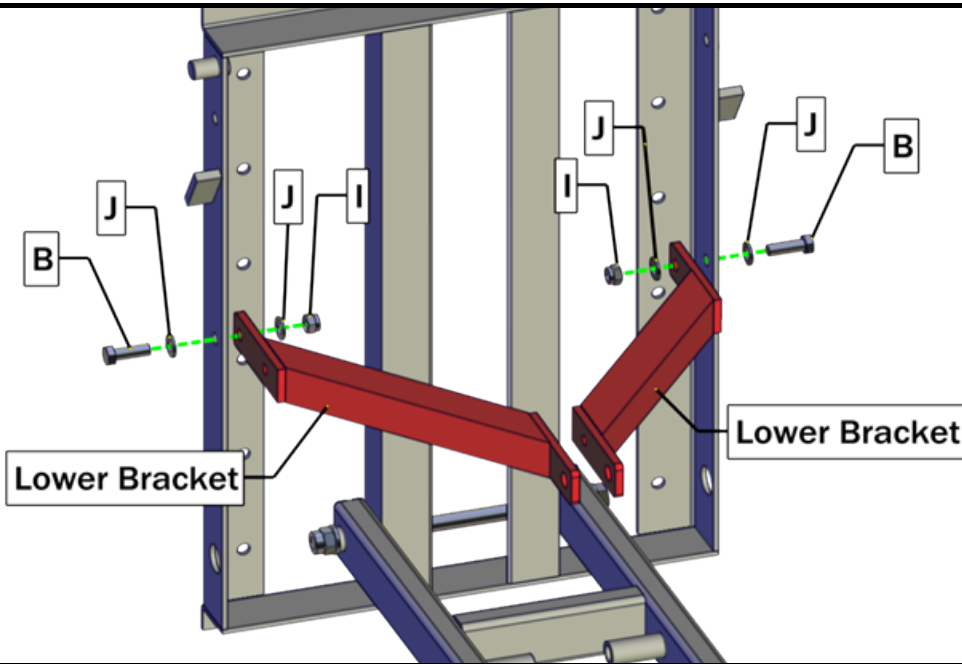

STEP #4 Upper Brackets & Upper Extension Arms

Attach the (2) upper brackets & (2) upper extension arms to the frame assembly using the following:

Bolt "C" - 12mm x 3" (2)

"J" - 12mm steel washer (4)

"K" - 12mm nylon washer (4)

"I" - 12mm hex nut (2)

Do not overtighten as this is a pivot point of the system. Snug Tighten.

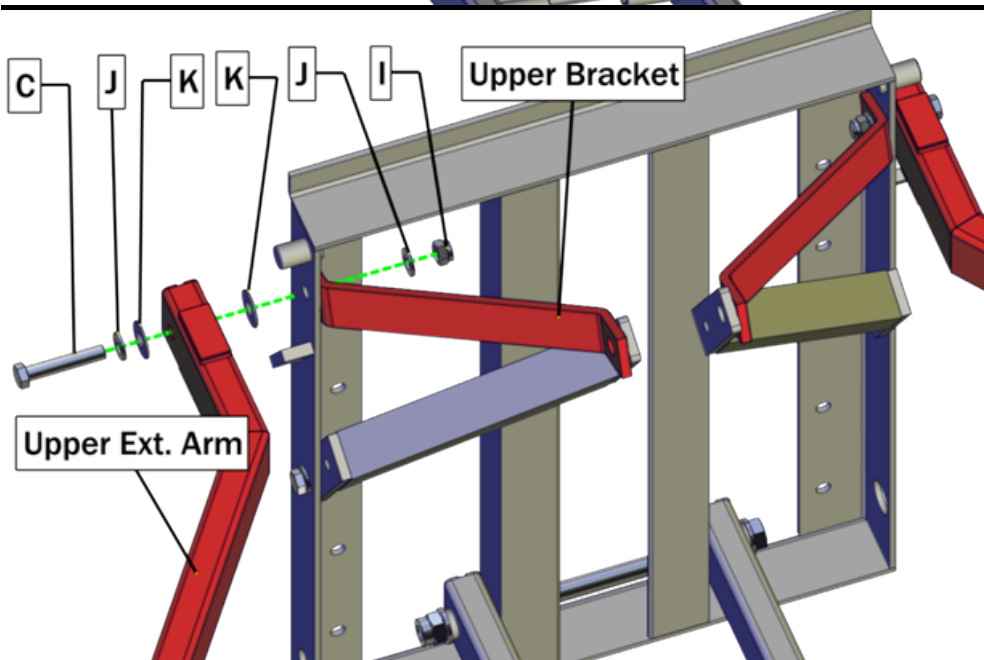

STEP #5 Height Actuator to Lower Extension Arm

Attach the height actuator to the lower extension arm using the following:

Bolt "A" - 16mm x 10.75" (1)

"F" - 16mm steel washer (2)

"G" - 16mm nylon washer (2)

"E" - 16mm hex nut (1)

Nylon washers go between height actuator and lower extension arm.

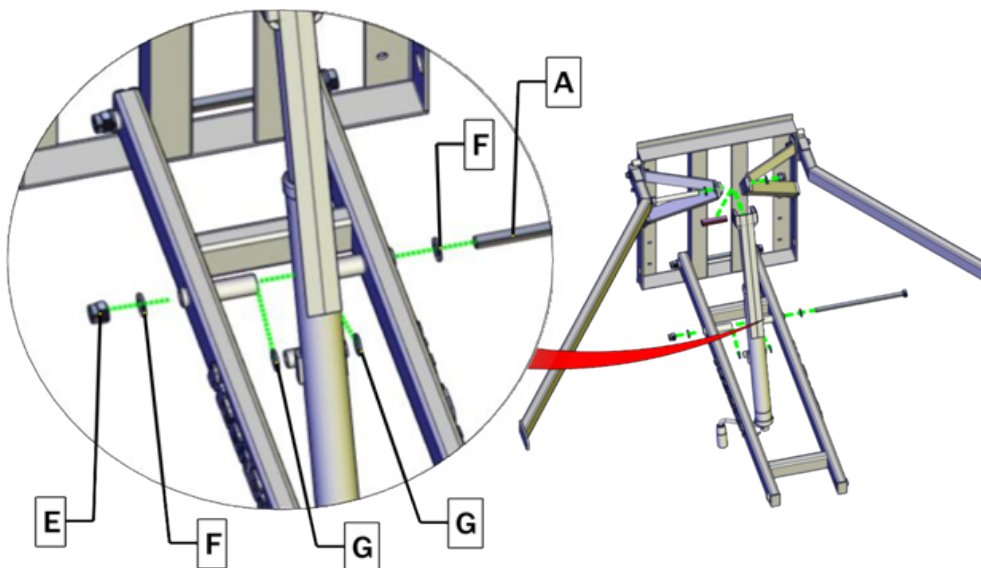

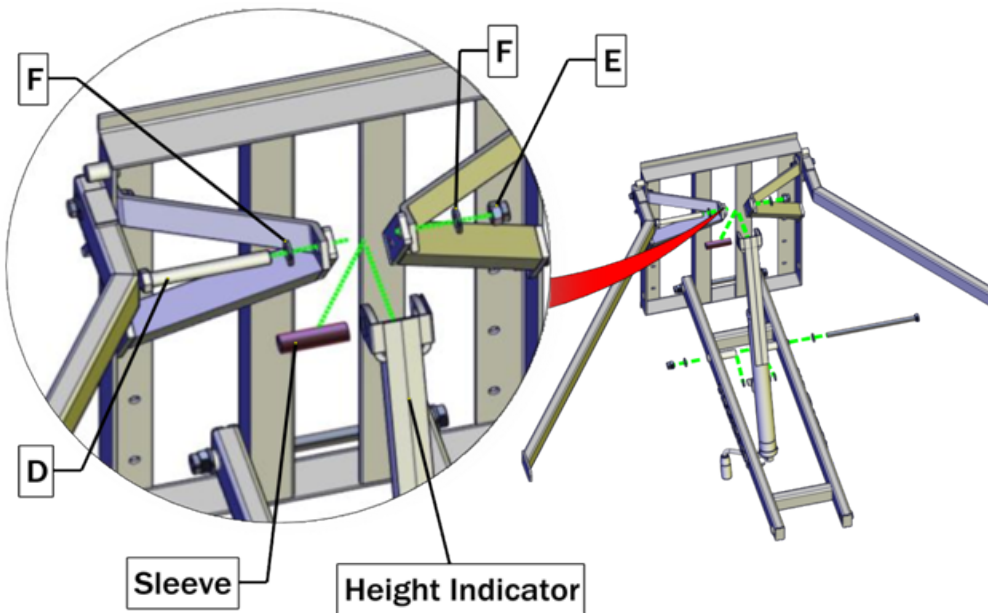

STEP #6

Height Actuator & Height Indicator to Bracket Assembly

Attach the height actuator & height indicator to the upper bracket assembly using the following.

Bolt "A" - 16mm x 10.75" (1)

"F" - 16mm steel washer (2)

"E" - 16mm hex nut (1)

Height Indicator (1)

Sleeve is inserted through the actuator, and bolt D slides through the sleeve.

STEP #7

Backboard attachment to Lower Extension Arm

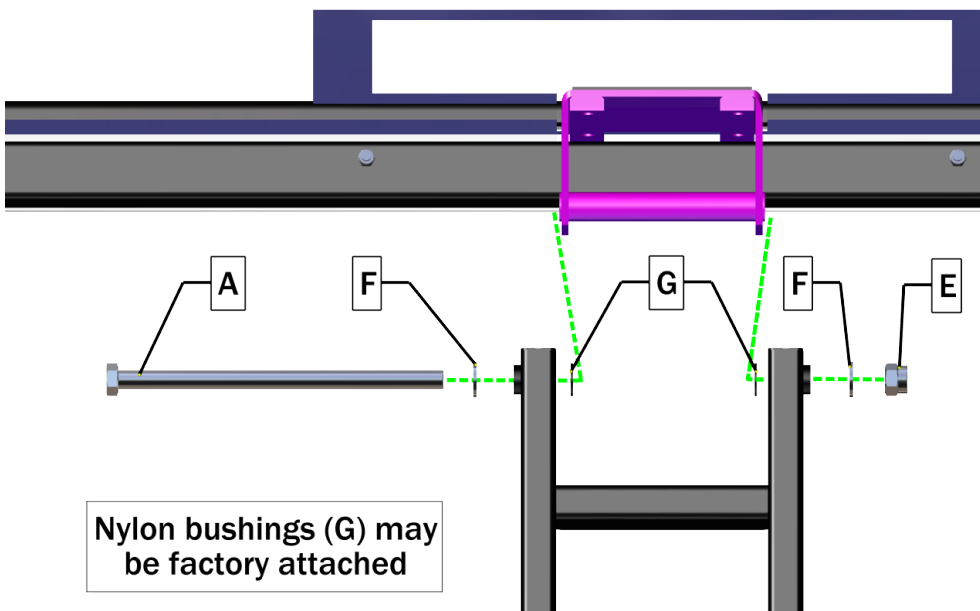

⚠ WARNING

To prevent serious injury or death, if using a stepladder, make sure it is in good condition, setting on a level and stable surface and do not exceed its weight rating.

Use three or four people to raise backboard assembly. Each person should be in good physical condition and capable of lifting at least 90-100 lbs (40-45 kg) each.

Rotate the handle of actuator and place the extension arm in the lowest bottom position before attaching the backboard.

STEP #8

Upper Extension Arms to the Backboard

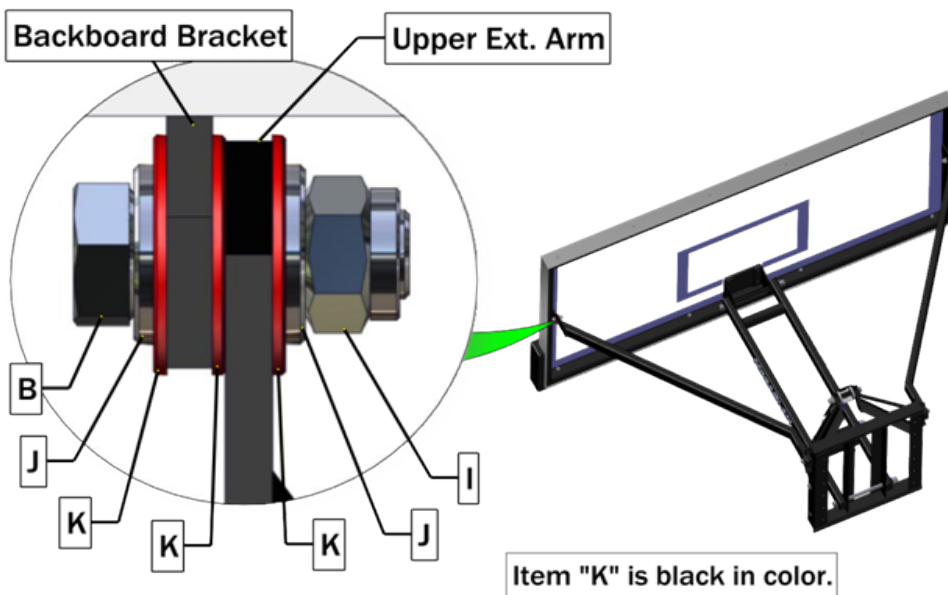

Attach the upper extension arms to the backboard using the following:

Bolt "B" - 12mm x 1.5" (2)

"J" - 12mm steel washer (4)

"K" - 12mm nylon washer (6)

"I" - 12mm hex nut (2)

Do not overtighten as this is a pivot point of the system. Snug Tighten.

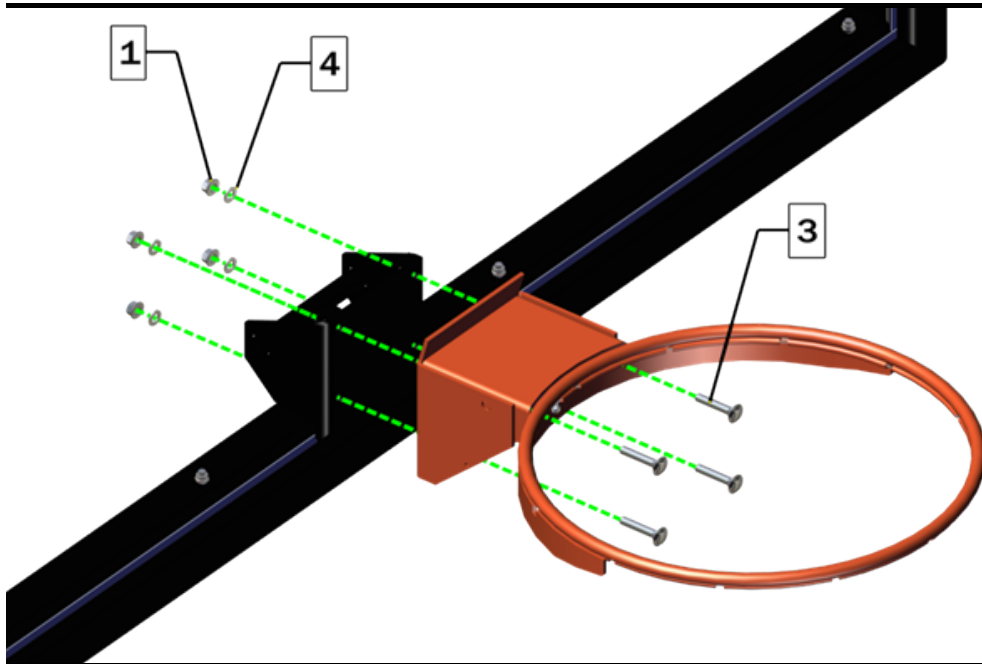

STEP #9 Rim Attachment

Attach the rim to the backboard using the following:

Bolt "3" - 10mm carriage bolt (4)

"4" - 10mm steel washer (4)

"1" - 10mm flange nut (4)

Make sure rim is level before tightening.

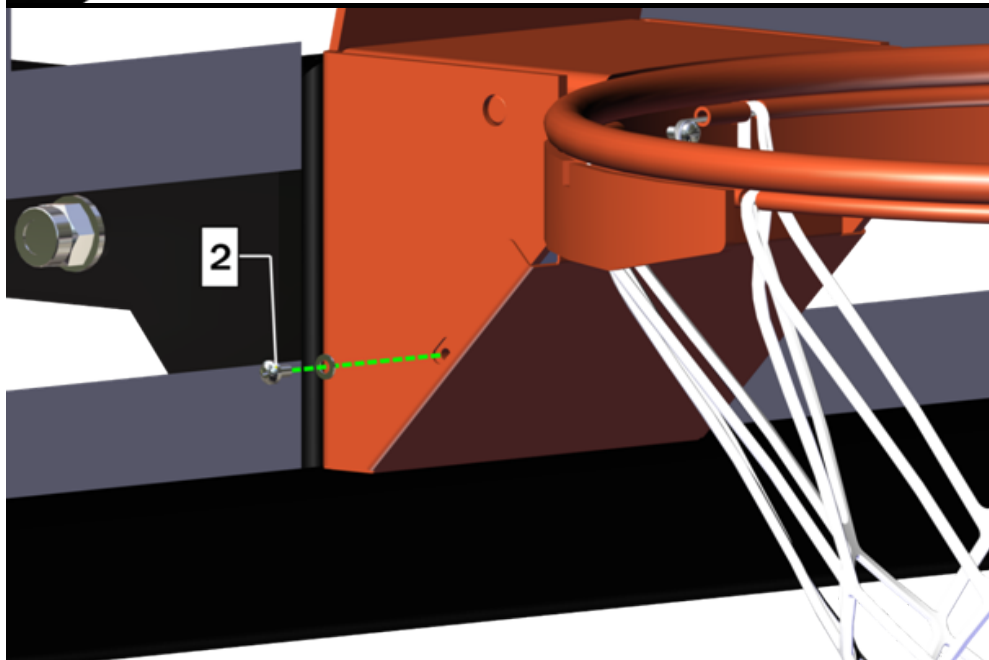

STEP #10 Rim Plate Attachment

Attach the rim plate to the rim using the following:

"2" - Machine Screw (2)

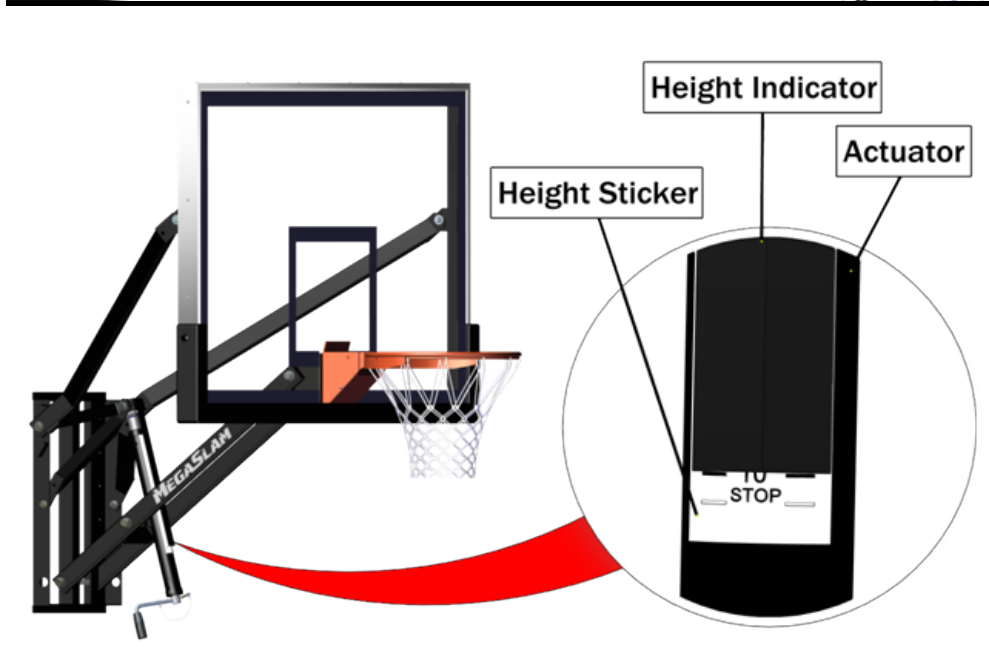

STEP #11 Height Sticker Attachment

Rotate the handle of actuator and position the rim 10' above the playing surface.

Measure the distance for accuracy.

Align the height indicator with the 10' mark on the decal and place the decal on surface of the actuator.

STEP #12 Maintenance

Like any piece of hardware proper maintenance is required. Several factors such as the environment, organic materials, herbicides, pesticides, excessive use, or misuse can eventually cause the system to require periodic maintenance. Failure to do so could result in system failure, property damage, or even personal injury.

- a) Keep all organic materials (grass clippings, garbage, etc.) away from the steel pole or base plate to alleviate any chance of rust penetrating the powder coated finish.
- b) Clean the backboard periodically with water and a soft cotton cloth. Approved glass cleaners work as well to maintain the clear view glass backboard. To properly clean the system components use a soft, non-abrasive cloth and water with a mild detergent. Do not use abrasive materials to clean as it could damage the powder-coated finish on your basketball system.
- c) If you see any signs of rust on the system remove the loose paint, gently sand the area, and apply outdoor enamel gloss paint to the affected area.

STEP #13 Routine System Inspection

Before each use inspect the basketball system for any signs of the following:

- Loose nuts and bolts
- All parts and components for excessive wear and tear
- Any signs of rust or corrosion

If replacement parts are needed, only replacement parts from Mega Slam Hoops, LLC should be used in the repair process. Use of other parts may cause the system to fail resulting in serious injury or death and will void the manufacturers' limited lifetime warranty